

Learning Management based on E-Learning in STMIK Muhammadiyah Jakarta

Hamid Al-Jufri^a, ^aMuhammadiyah University of Prof. Dr. Hamka, Email: ajufri@uhamka.ac.id

This study aims to produce a learning management model based on e-learning in an effort to improve the quality of learning based on e-learning. This research was conducted with a Research and Development (R&D) approach. The stages of this research include three stages, namely: (1) Preliminary studies (2) Model development (3) Validity test. The results showed that a learning based e-learning model really helped students in learning, and obtained significantly higher learning outcomes ($P > 0.95$) compared to students learning with conventional learning methods. The learning based e-learning management model can improve the effectiveness of lecturer and student performance, due to the more efficient use of place, time, cost, and energy, so that this e-learning based learning model is effective to improve the quality of teaching and learning.

Key words: *Learning Management, Computer Technology and Internet.*

Introduction

Technological advancements in presenting information systems have developed tremendously, which shows people can access information instantly in various forms, even reaching into diverse fields from education, business, work procedures, management, to household life.

E-learning is "learning supported by digital electronic devices and media" and m-learning is "e-learning using cellular devices and wireless transmission" (Hoppe et al., 2003: 255). E-learning is an alternative to traditional education and can also be a complement to it (Basak, et al. 2018). According to Rosenberg (2001) and Wentling et al. (2000), e-learning is usage of Internet technology that can provide various solutions to increase knowledge and performance.



Learning is a process which occupies an important role in moulding the structure of our personality and behaviour. It develops socially accepted behaviours and also there is equal chance of building the negative side of human behaviour (Darmaraj, 2015). Learning is defined as a deliberate effort by educators to support student learning activities (Kusumandari & Istyarini, 2015).

Learning based e-learning, is a field that is growing rapidly and getting a lot of attention in the world of education, and has opened the door for the birth of the world library. In addition, the means of e-mail or electronic mail encourage the education community to take advantage of the communication between students and educators more effectively and efficiently.

E-learning is an effective learning process that is produced by combining the delivery of digital material consisting of support and services in learning (Waller 2001; Glossary, 2001 and Hartley, 2001).

Learning based e-learning system is a form of learning implementation that utilises technology and is not limited by space and time, meaning that a learning step can always be done both synchronously and asynchronously. To achieve a knowledgeable society as a result of a concept that has been known as a learning society, knowledge must be something that can be managed well so that it can be used for the progress of individuals, organisations, and society as a whole. In e-learning activities, the lecturers and learning participants revealed that they knew each other more. The self-study participants acknowledged that they knew the lecturer better through e-learning activities. In addition, e-learning teachers are also active in conducting conversations (communication) with parents of students via telephone and e-mail, because these parents are partners in e-learning activities. Likewise, communication with fellow e-learning participants. Wherever we are, one thing that needs to be emphasised and understood is that e-learning cannot completely replace conventional learning activities in the classroom (Lewis, 2002 and Reddy, 2002).

E-learning technology is inevitable in that learning based e-learning is beneficial for lecturers and students, therefore learning based e-learning is already in use, but must be managed so that the teaching and learning process runs well.

The formulation of the problems in this study are :

- a. What are the goals of learning based e-learning management?
- b. What are the steps or processes of learning management based on e-learning?
- c. What is the final form of learning based e-learning management?

Research Methods

This research uses a research and development approach. R&D stages can be simplified into three stages: conducting a preliminary study, developing a model and validating the model as shown in the following chart:

Preliminary Study Model, Product Model Product, Validation Development

Figure 1. Research and Development Steps

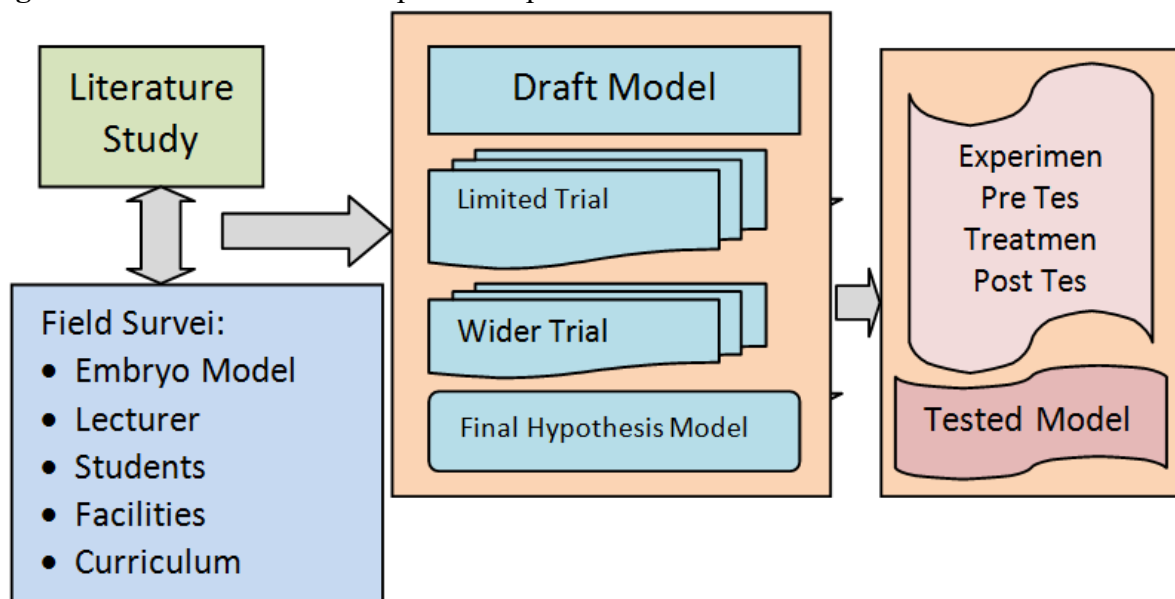

Based on the results of a preliminary study that refers to the theoretical foundations of the results of the literature review, an initial draft of the e-learning based learning model has been prepared utilising multimedia that adjusts to the situation and conditions in the field to produce a draft model. The draft model developed in this study was tested on a limited basis repeatedly until a model that was suitable for field conditions was found. In line with the implementation of the observations carried out, the results of these observations are used as material to revise the model that will be tested in the next stage, to find out the learning outcomes after each trial is given a post-test.

A model can be accepted as a sufficient model only if the model successfully passes the validation test. This validation test requires standards. Model validation is carried out through experiments. While software validation is carried out through the assessment of computer experts.

Learning software assessment refers to content, management, ease of use, design and program models. The assessment results illustrate that the software needs to be improved as shown in Table 1 below:

Table 1: Software Assessment Results

Criteria	Improvement
Content	Material starts from SAP
Management	Adjusted to field conditions
Usage	Give operational instructions
Design	<i>Layout screen</i> do not confuse
Program Model	The Tutorial Program Model is explained in English and Indonesian

Learning software is improved and refined according to the advice of experts who have been asked to provide assessments. The results of improvements are tested on students. In the validation test there is a management model utilising e-learning that is developed. The standards used are (1) the impact of the model on student learning activities, (2) the impact of the model on lecturer performance. The validation test was conducted in the even semester of the 2007-2008 academic year before the pretest was held, then after the model was implemented, it was given a post-test. After completing the experiment and post-test, a statistical process is performed to find out the efficacy of the model, namely the pre-test and post-test difference test, the difference between the control group and the experimental group.

Research Results

The initial survey is a preliminary study conducted to find out and identify e-learning patterns that are currently taking place. The results of the initial survey serve as a result of consideration in developing the learning based e-learning management model.

The Purpose of Lecturers in Learning based E-Learning

Table 2: The Purpose of Lecturers in Learning based E-Learning

Questions	Have	Not yet
Has learning based e-learning become a solution in IT learning?	7 (100%)	-
Is learning based e-learning all the way to BAU and BAAK (integrated)?	3 (43%)	4 (57%)
Are BAU and BAAK involved in the learning based e-learning process?	-	7 (100%)

From the table above, it is concluded that (100%) of seven lecturers from the three campuses stated that they have become a solution in learning based on e-learning to learn IT; (57%) of 7 lecturers who teach learning based on e-learning stated that they have not yet reached General Administration Bureau (GAB) and Academic and Student Administration Bureau

(ASAB); (43%) stated that in the sense of being interviewed, the lecturer was only limited to the notification that the existence of learning based e-learning was not yet integrated, and (100%) the lecturer stated that he did not involve GAB and ASAB in teaching and learning in learning based on e-learning.

Learning Facilities or Facilities based on E-learning

Table 3: Learning Facilities or Facilities based on E-Learning

Questions	Yes	No
Is the computer laboratorium sufficient and meets the standards in learning based e-learning?	10 (100%)	-
Is learning based e-learning managed?	-	10 (100%)
Must learning based e-learning be managed?	10 (100%)	-

From the above table it is concluded (100%) of ten Computer Service Center (CSC) employees stated that the available computer is sufficient for e-learning based learning, (100%) stated learning based e-learning is not yet managed, and (100%) stated it must be managed so that the learning process runs well.

GAB and ASAB Views in Learning Based E-Learning

Table 4: GAB and ASAB Views in Learning Based E-Learning

Questions	Yes	No
Do GAB and ASAB know about learning based e-learning?	14 (61%)	9 (39%)
Do you understand learning based e-learning?	9 (39%)	14 (61%)
Are you involved in learning based e-learning?	-	23 (100%)
Must learning based e-learning be managed ?	23 (100%)	-
Would you like to be involved in learning based on e-learning to find out that students have paid or at the same time know student development?	23 (100%)	-

From the table above, it is concluded that (61%) stated that they are aware of learning based e-learning and (39%) stated that they are not aware of learning based e-learning, (39%)

understand learning based e-learning and (61%) stated they do not understand, (100%) are not involved, and must be managed, (100%) want to be involved in learning management based on e-learning and know the payment and development of students.

Students' Views of the Design and Performance Aspects of Lecturers in Learning Based on E-Learning

Table 5: Students' Views of the Design and Performance Aspects of Lecturers in Learning Based on E-Learning

Questions	Good	Enough	Less
Is the program used in learning based e-learning?	38 (37,6%)	52 (51,5%)	11 (10,9%)
What are the steps to enter into learning based e-learning?	25 (24,7%)	63 (62,4%)	13 (12,9%)
Is there clarity of terms in learning based e-learning?	27 (26,7%)	55 (54,5%)	19 (18,8%)
Is there clarity of user instructions based on e-learning?	38 (37,6%)	53 (52,5%)	10 (9,9%)
Is learning based e-learning display sufficient?	49 (48,5%)	42 (41,6%)	10 (9,9%)
Is there clarity of the material description of each chapter?	28 (27,7%)	54 (53,5%)	19 (18,8%)

From the table above it can be concluded that the design of learning based e-learning from the opinions of 101 students studying with e-learning based learning on STMIK Muhammadiyah Jakarta stated: the program used in learning based e-learning, (37.6%) stated both, (51.5%) stated that it was good enough, and (10.9%) said it was not good; the steps in learning based e-learning, (24.7%) stated that it was good, (62.4%) said it was sufficiently good, and (12.9%) stated that it was not good; the clarity of terms in learning based on e-learning, (26.7%) stated that it was good, (54.5%) said it was quite good, and (18.8%)) stated that it was not good; the clarity of user instructions in learning based e-learning, (37.6%) said it was good, (52.5%) said it was quite good, and (9.9%) stated that it was not good; the display of learning based e-learning (48.5%) stated good, (41.6%) stated unfavorable, and (9.9%) stated unfavorable; clarity of description per chapter (27.7%) stated that it was good, (53.5%) said it was not good.

Student Views on Lecturer Performance in Learning Based on E-Learning

Table. 6: Student Views on Lecturer Performance in Learning Based on E-Learning

Questions	Yes	Sometimes	Never
Do your lecturers give time to communicate in learning based e-learning?	37 (36,6%)	49 (48,5%)	15 (14,9%)
Are each lesson or chapter given a learning task or exercises ?	52 (51,5%)	41 (40,6%)	8 (7,9%)
Have the assignment checked and commented on?	37 (36,6%)	39 (38,6%)	25 (24,8%)
Can students express their opinions freely?	55 (54,5%)	34 (33,7%)	12 (11,8%)
Is the time given in learning based e-learning limited?	54 (53,5%)	30 (29,7%)	17 (16,8%)
Do your lecturers know that students are downloading learning based e-learning?	60 (59,4%)	-	41 (40,6%)

From the table above, conclusions can be drawn on the performance of lecturers in learning based e-learning from the opinions of 101 students who learn with learning based e-learning on the campus : lecturers give time to communicate in learning based e-learning, (36, 6%) stated that it was good, (48.5%) said it was good enough, and (14.9%) said it was not good; each lesson or chapter was given a task or training in learning based on e-learning, (51.5%) stated good, (40.6%) stated that it was quite good, and (7.9%) stated that it was not good; the tasks were examined and commented on in learning based e-learning, (36.6%) stated that it was good, (38.6%) stated that it was good enough, and (24.8%) said it was not good; students able to expresstheir opinions freely in learning based e-learning, (54.5%) stated that it was good, (33.7%) said it was quite good , and (11.8%) stated that it was not good; learning based e-learning time was limited (53.5%) stated that it was good, (29.7%) said it was not good, and (16.8%) said it was not good, when students downloaded learning based e-learning the lecturers knew, (59.8%) said yes, (40.6%) said no.

Steps in the Learning Based e-Learning Management Model

This learning based e-learning management model will be applied first, so there are some conditions including:

- a. Students must pay tuition fees through the BANK,
- b. Students submit proof of payment that has been authorised by the BANK to the financial administration (GAB),



- c. The data is given to the ASAB for filling out study plan forms for students who take e-learning based learning.
- d. ASAB provides information to lecturers on classes, times, and courses that will be taught with e-learning based learning.
- e. Students register themselves at the e-learning website at the address <http://www.aljufri-elearning.com> and students must have e-mail.
- f. Re-checking by ASAB or lecturers to enable students to enter the class taught by the lecturer or taken by students.
- g. Students can already open courses taken.
- h. The learning model based on e-learning can be assessed perchapter, it can be arranged for the meeting to take effect either hourly or daily, and for each chapter there will be exercises to be filled out by students, students can find out the results directly through learning e-learning.
- i. Mid-term exams grades are sent to ASAB via computer.
- j. ASAB announces the results of mid-term exams to students through e-learning, students can see directly through e-learning, and the end of the semester exam.

Student development can be monitored by e-learning based learning management models from both ASAB and lecturers, how many times students open the e-learning website.

Figure 2. Steps in the Learning Based E-Learning Management Model

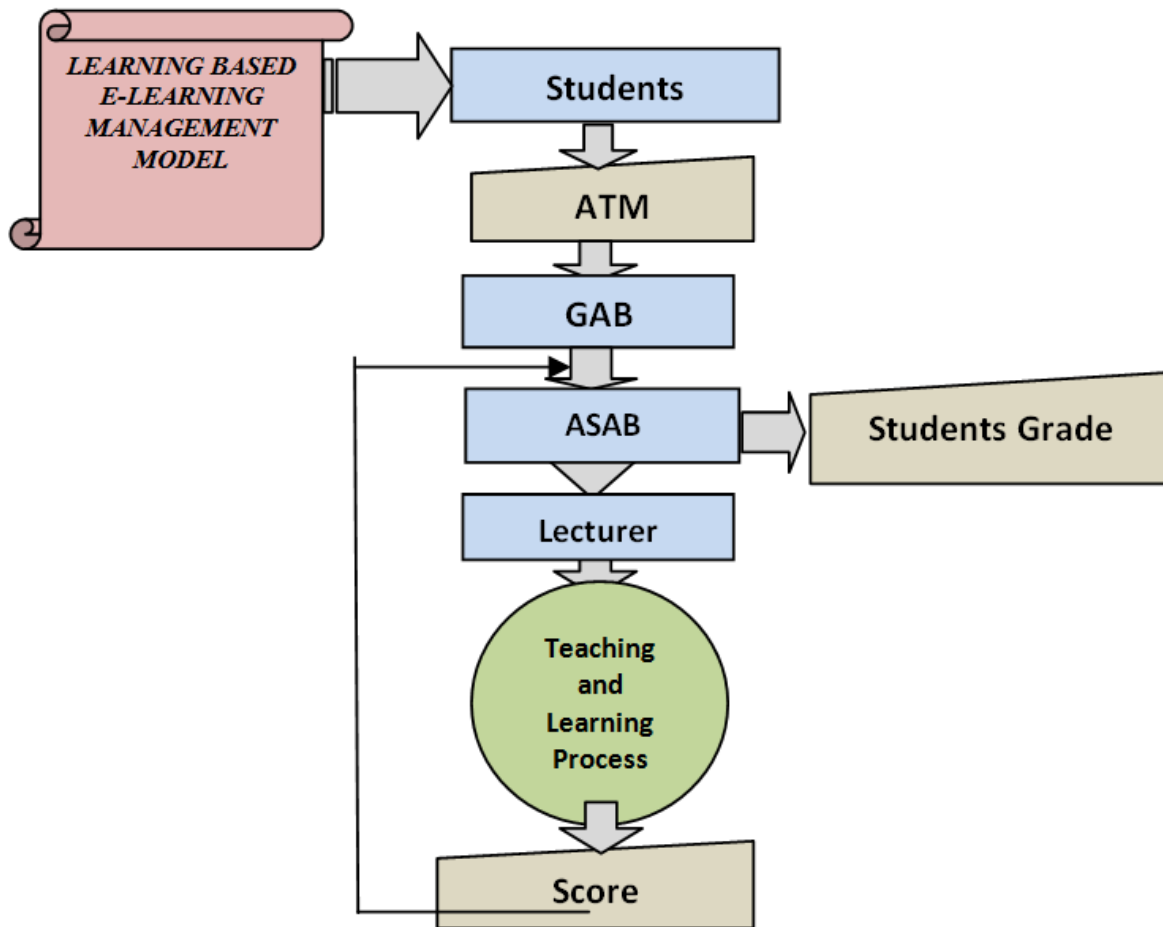

Learning Based E-Learning Management Effectiveness Test Results

In the learning based e-learning management model, the result is effective in learning based e-learning in terms of place, whether students do their learning on campus (LAB), at Internet Cafes, or at home. Time, in terms of length of student learning using the Internet. Costs, in terms of how many students spend on e-learning based learning in using the Internet. Learning outcomes, taken from training, assignments, mid-terms, and final exams are combined into one.

Figure 3. The Results of the Learning Based E-Learning Management Model Process

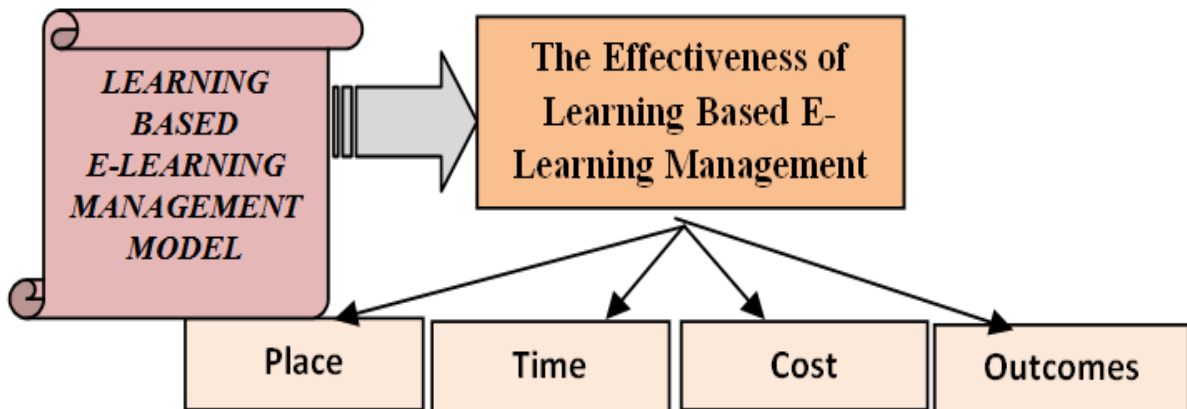

Table 3: The Results of the Management Process Model of Comparison of Conventional Learning with Management of E-learning Based Learning based on ELearning.

Conventional	<i>e-Learning</i>
PLACE	
Static	Dynamic, Flexible, meaning anywhere
TIME	
3 SKS X 45 = 135 minutes = 2 hours 15 minutes	Average = 55 minutes
COST	
If students spend money on school fees, estimated allowance Rp 15.000	Using a 4,000 internet cafe for 1 hour
AVERAGE STUDENT RESULTS	
60	72

Before explaining about the e-Learning-based learning management model, the following questionnaire results, Planning (X1), Organising (X2), Supervision (X3), and E-Learning Based Learning Effectiveness will be presented below:

Table 7: Correlation Between Research Variables

			Rating Planning (X1)	Organisations Rating (X2)	Supervision Rating (X3)	Effectiveness of Learning based e-Learning(Y)
Spearman's rho	Rating Planning (X1)	Correlation Coefficient	1,000	,634(**)	,772(**)	,838(**)
		Sig. (2-tailed)	.	,000	,000	,000
		N	27	27	27	27
	Organisations Rating (X2)	Correlation Coefficient	,634(**)	1,000	,704(**)	,548(**)
		Sig. (2-tailed)	,000	.	,000	,003
		N	27	27	27	27
	Supervision Rating (X3)	Correlation Coefficient	,772(**)	,704(**)	1,000	,492(**)
		Sig. (2-tailed)	,000	,000	.	,009
		N	27	27	27	27
	Effectiveness of Learning based e-learning (Y)	Correlation Coefficient	,838(**)	,548(**)	,492(**)	1,000
		Sig. (2-tailed)	,000	,003	,009	.
		N	27	27	27	27

** Correlation is significant at the 0.01 level (2-tailed).

Based on the calculation above, it shows that, X3 variable has the lowest relationship with Y variable compared to other variables. That is, the rating of supervision in the effectiveness of learning based on e-learning needs to be improved, especially concerning: First, the monitoring system of payment using electronic means. This happens because the existing facilities are still not optimally meeting the needs of providing services to students when making payments by electronic systems. Second, the software monitoring system for payment services. This, related to the availability of software still needs to be developed in accordance with the demands of student needs. Broadly speaking, the relationships that occur between the variables studied in this study can be seen in: Figure 3.

Figure 4. Constellation of Relationships Between Research Variables Based on Research Results

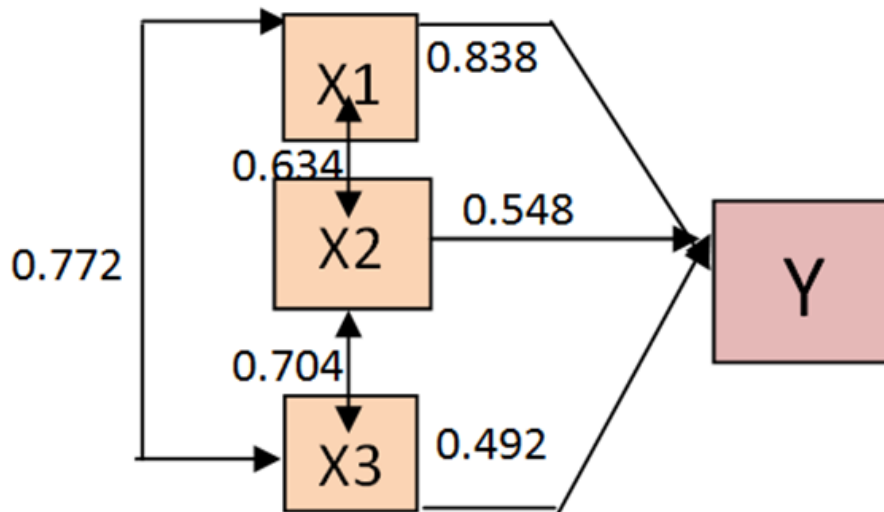

Discussion

A pleasant learning situation for students will lead to feelings of interest in students to learn what they enjoy getting more intensive. This will be the opposite if the learning situation is not pleasant, as Winkel (1996) explained, "Unhappiness will inhibit learning, because it does not give birth to a positive attitude and does not support learning interest." The effectiveness of a management model can be reviewed from the way it is implemented in teaching and learning activities, and measurements are made based on place, time, cost and student learning outcomes using e-learning based learning management with conventional learning. It should be emphasised here that the place, time, cost, and learning outcomes seen are after students learn by using e-learning based learning management.

Online learning changes the learning experience in the classroom, provides additional assistance in learning for students and enables the formation of a stable and integrated learning community, helping students to develop some generic skills in finding and evaluating information for their learning (Vine, 2016 and Johnston, 2010).

According to Duderstadt et al. (2002), e-learning is used in a study environment study with special interest in the web to consider various applications electronic technology. Sharma and Kitchens (2004) state that e-learning includes learning with the help of a web-based training facility such as virtual universities and classrooms that connect digitally distance learning. E-learning innovation can be determined as a form of technological or methodological e-learning that is considered as new by potential users (Fischer, 2013). According to Ally (2005), e-learning drama plays an important role in any country in the growth of education and offers opportunities for developing countries to enhance their education development.



The researchers found that e-learning factors included bandwidth (Homan and Macpherson, 2005), choosing teachers who support ICT (Carr, 1999; Iqbal and Ahmad, 2010; Levy, 2003; Nawaz and Khan, 2012; Poldoja et al. 2012), too faculty interests (Forman et al., 2002; Qureshi et al., 2012), power failure (Sangi, 2008; Iqbal and Ahmad, 2010), lacking a formal implementation process (Masoumi and Lindstrom, 2012), students who support ICT (Oliver, 2001; Qureshi et al., 2011), rejecting the object of learning (LO) in the area language (Khattak, 2010), socio-cultural norms (Iqbal and Ahmad, 2010), broadband Internet accessibility (Farid et al., 2014), costs of mobile internet, practical set up for practically oriented training, and literacy levels (Farid et al., 2015).

This e-learning based learning management model was effective in improving the quality of learning in terms of where learning has freedom, free learning time, the cost of learning is very efficient in terms of student spending per day to campus, and e-learning based learning management is able improve student learning achievement.

Conclusion

The learning based e-learning management model was effective in improving student learning achievement. Research findings in trials provide an overview of increasing student learning, outcome evaluation scores, and research findings in validation tests show significantly higher and significantly different results when compared with learning outcomes obtained through ongoing learning. The learning based e-Learning management model is effective to improve the ability to process data, search for information and improve student learning outcomes. The research findings show that the learning management model based on e-learning brings benefits to students who have a computer science background because it can be done in groups or independently, either accompanied or not by lecturers, and students can control their own learning strategies.



REFERENCE

- Ally M. (2005). Using learning theories to design instruction for mobile learning devices. *Mobile Learning Anytime Everywhere* (pp. 5–8), London, UK: Learning and Skills Development Agency
- Basak, Sujit Kumar, et al. (2018). E-Learning, M-Learning and D-Learning: Conceptual Definition and Comparative Analysis. *E-Learning and Digital Media* 2018, Vol. 15(4) 191–216
- Carr J. (1999). The role of higher education in the effective delivery of multimedia management training to small and medium-sized enterprises. *Educational Technology & Society* 2(2): 1–15
- Dharmaraj, William. (2015). *Learning and Teaching*, Thailand: Centre For Distance Education
- Duderstadt JJ, Atkins DE and Van Houweling DE. (2002). *Higher Education in the Digital Age: Technology Issues and Strategies for American Colleges and Universities*. Rowman & Littlefield Publishers/USA
- Farid S, Ahmad R, Niaz I, et al. (2014). Identifying perceived challenges of e-learning implementation. In: *First international conference on modern communication & computing technologies (MCCT'14)*, 26–28 February, Nawabshah, Pakistan. Farid S, Ahmad R, Niaz IA, et al. (2015) Identification and prioritization of critical issues for the promotion of e-learning in Pakistan. *Computers in Human Behavior* 51: 161–171
- Fischer H. (2013). *E-Learning im Lehralltag: Analyse der Adoption von E-Learning-Innovationen in der Hochschullehre*. Springer-Verlag
- Forman D, Nyatanga L and Rich T. (2002). E-learning and educational diversity. *Nurse Education Today* 22(1): 76–82
- Hartley, Darin E. *Selling e-Learning*, American Society for Training and Development, 2001.
- Homan G and Macpherson A. (2005). E-learning in the corporate university. *Journal of European Industrial Training* 29(1): 75–90
- Hoppe HU, Joiner R, Milrad M, et al. (2003). Guest editorial: Wireless and mobile technologies in education. *Journal of Computer Assisted Learning* 19(3): 255–259



- Iqbal MJ and Ahmad M. (2010). Enhancing quality of education through e-learning: The case study of Allama Iqbal Open University. *Turkish Online Journal of Distance Education* 11(1): 84–97
- Glossary, (2001). “Glossary of e-Learning Terms” , LearnFrame.Com
- Johnston, N. (2010). Is an Online Learning Modul an Effective Way to Develop Information Literacy Skills? *Australian Academic & Research Libraries*, 41(3), 207.
- Khattak D. (2010). Development of multimedia instruction objects for delivery in a localized e-learning environment. Doctoral Dissertation, Allama Iqbal Open University, Islamabad, Pakistan
- Kusumandari, Rafika Bayu & Istyarini, Character Education Development Model-based E-Learning and Multiple Intelegency in Childhood in Central Java, *Global Journal of Computer Science and Technology: H Information & Technology* Volume 15 Issue 3 Version 1.0 Year 2015
- Lewis, Abel, M. dan Lewis, P. (2005). *Universal Design For Learning: A Statewide Improvement Model For Academic Success.*
- Levy S. (2003). Six factors to consider when planning online distance learning programs in higher education. *Online Journal of Distance Learning Administration* 6(1): 1–19
- Masoumi D and Lindstrom B. (2012). Quality in e-learning: A framework for promoting and assuring € quality in virtual institutions. *Journal of Computer Assisted Learning* 28(1): 27–41
- Nawaz A and Khan MZ. (2012). Issues of technical support for e-learning systems in Higher Education Institutions. *International Journal of Modern Education and Computer Science* 4(2): 38–44
- Oliver R. (2001). Assuring the quality of online learning in Australian higher education. In: *Proceedings of moving online II conference*, pp. 222–231. Lismore: Southern Cross University
- Poldoja H, V ~ €aljataga T, Laanpere M, et all. (2012). Web-based self-and peer-assessment of teachers’ digital competencies. *World Wide Web* 17(2): 255–269
- Qureshi IA, Ilyas K, Yasmin R, et al. (2012). Challenges of implementing e-learning in a Pakistani university. *Knowledge Management & E-Learning: An International Journal (KM&EL)* 4(3): 310–324



- Qureshi QA, Nawaz A and Khan N (2011). Prediction of the problems, user-satisfaction and prospects of e-learning in HEIs of KPK, Pakistan. *International Journal of Science and Technology Education Research* 2(2): 13–21
- Reddy, V. Venugopal and Manjulika, S. (2002). *From Face-to-Face to Virtual Tutoring: Exploring the potentials of E-learning Support*. Indira Gandhi National Open University
- Rosenberg MJ (2001) *E-Learning Strategies for Delivering Knowledge in the Digital Age*. New York: McGraw-Hill
- Sangi NA (2008) Electronic assessment issues and practices in Pakistan: A case study. *Learning, Media and Technology* 33(3): 191–206
- Sharma SK and Kitchens FL (2004) Web services architecture for m-learning. *International Journal of Mobile Communications* 2(1): 203–216
- Vine, M. M. (2016). Exploring Local Level Factors Shaping the Implementaion of a Blended learning Modul for Information and Geospatial Literacy in Ontario. *The Canadian Journal for the Scholarship of Teaching and Learning*, 7(2), 1–16.
- Waller, Vaughan and Wilson, Jim. (2001), “A Definition for E-Learning” in *Newsletter of Open and Distance Learning Quality Control*. October 2001.
- Wentling TL, Waight C, Gallaher J, et al. (2000) *E-learning: A review of literature*. In: *Knowledge and Learning Systems Group*. USA: University of Illions at Urbana-Champaign, pp. 1–73